



FLECK 2510 AIO CONTROL VALVE

SERVICE MANUAL



IMPORTANT PLEASE READ:

- The information, specifications and illustrations in this manual are based on the latest information available at the time of release. The manufacturer reserves the right to make changes at any time without notice.
- This manual is intended as a guide for service of the valve only. System installation requires information from a number of suppliers not known at the time of manufacture. This product should be installed by a plumbing professional.
- This unit is designed to be installed on potable water systems only.
- This product must be installed in compliance with all state and municipal plumbing and electrical codes. Permits may be required at the time of installation.
- It is established that when daytime water pressure exceeds 80 psi (5.5 bar), the maximum pressure rating of 125 psi (8.6 bar) can be exceeded. A pressure regulator must be installed on this system or warranty is voided.
- Do not install the unit where temperatures may drop below 32°F (0°C) or above 120°F (52°C).
- Do not place the unit in direct sunlight. Black units will absorb radiant heat, increasing internal temperatures.
- Do not strike the valve or any of the components.
- Warranty of this product extends to manufacturing defects. Misapplication of this product may result in failure to properly condition water, damage to product, or personal injury.
- A prefilter should be used on installations in which free solids are present.
- In some applications local municipalities treat water with Chloramines. High Chloramine levels may damage valve components.
- Correct and constant voltage must be supplied to the controller to maintain proper function.
- The system is intended to treat only potable quality water. It is not intended as the permanent primary treatment of water from a source that is contaminated, such as from radon, pesticides, insecticides, sewage or wastewater.
- This system is not intended for use by persons (including children) with reduced physical, sensory, or mental capabilities, or lack of experience and knowledge, unless they have been given supervision or instruction concerning use of the appliance by a person responsible for their safety.
- Children shall not play with the system.
- Cleaning shall not be made by children without supervision.

VALVE SPECIFICATIONS

Valve Material	Fiber-reinforced polymer
Inlet/Outlet	3/4", 1", or 1-1/4" NPT/BSP/Sweat
Cycles	3 or 5

Flow Rates (50 psi inlet) valve only

Continuous 15 psi drop	19 GPM (4.3 m ³ /hr)
Peak 25 psi drop	25 GPM (5.5 m ³ /hr)
Cv flow at 1 psi drop	4.8
Max Backwash 25 psi drop	17 GPM (3.9 m ³ /hr)

Dimensions

Distributor Pilot	1.05" O.D. (26.7 mm)
Drain Line	1/2" NPTF Quick-Connect
Injector System	1600, 1650
Mounting Base	2.5" - 8 NPSM
Height from Top of Tank	7.5" (191 mm)
Riser Tube Diameter	3/4" (19 mm)
Riser Height	1/4" below top of tank

Additional Information

Electrical Rating	24/110/220V 50/60 Hz
Pressure (Hydrostatic)	300 psi (20 bar)
Pressure (Working)	20-125 psi (1.4-8.5 bar)
Temperature	34-110°F (1-43°C)
Cold Water Valve: Deflector	1" inner diameter

TABLE OF CONTENTS

JOB SPECIFICATION SHEET	2
VALVE SPECIFICATIONS.....	3
INSTALLATION.....	4
DEFLECTOR INSTALLATION	4
REGENERATION STEPS	5
START-UP INSTRUCTIONS.....	5
TIMER OPERATION	6
SXT USER PROGRAMMING	7
DIAGNOSTIC PROGRAMMING MODE.....	7
2510 AIO SXT CONTROL VALVE ASSEMBLY	8
POWERHEAD ASSEMBLY	10
2510 VALVE ACCESSORIES	12
2510 VALVE CONVERSION ASSEMBLIES.....	13
BYPASS VALVE ASSEMBLY (PLASTIC).....	14
BYPASS VALVE ASSEMBLY (METAL)	15
TROUBLESHOOTING (2510).....	16
TROUBLESHOOTING (AIO).....	17
FLOW DATA & INJECTOR DRAW RATES	18
SXT WIRING DIAGRAM.....	19

JOB SPECIFICATION SHEET

Job Number: _____

Model Number: _____

Iron (ppm): _____

Tank Size: _____

1. Timer Program Settings:

A. Backwash: _____ Minutes

B. Air Draw: _____ Minutes

C. Rapid Rinse: _____ Minutes

INSTALLATION

Installation Overview

The AIO valve is designed for use when water containing contaminants subjected to oxidation is encountered. The water passes through the AIO valve then passes through the tank containing oxygen enriched filter media. The oxygen reduces all contaminants in the water to an oxide, or in the case of hydrogen sulfide gas, it is reduced to a molecule of acid.

Install the AIO valve after the supply lines to the outside faucets (unless outside faucets need to be free of contaminants in water). The AIO valve is generally installed before a water softener or any taste/odor cartridges, if applicable.

Due to the release of air during regeneration, the drain line should be anchored throughout the run and secured at the end of the drain line. The drain line should be sized for the backwash rate and friction loss.

The drain line flow control should accommodate the size tank and backwash rate for the filter media being used.

The injector size (slow rinse rate based on pressure) should be sized the same as the service flow rate of the filter media being used.

Water Pressure

A minimum of 20 psi (1.4 bar) of water pressure is required for regeneration valve to operate effectively.

CAUTION Water pressure is not to exceed 125 psi (8.6 bar), water temperature is not to exceed 110°F (43°C), and the unit cannot be subjected to freezing conditions.

Electrical Facilities

An uninterrupted alternating current (120 VAC) supply is required. Please make sure your voltage supply is compatible with your unit before installation.

NOTE: Other voltages are available. Please make sure your voltage supply is compatible with your unit before installation. The power source should be constant. Be certain the power adapter is not on a switched outlet.

Existing Plumbing

Condition of existing plumbing should be free from lime and iron buildup. Piping that is built up heavily with lime and/or iron should be replaced. If piping is clogged with iron, a separate iron filter unit should be installed ahead of the water softener.

Location Of Softener/Filter/AIO Drain

You must have an air gap on the drain line to prevent back flow of drain water into the system. A 2x the drain line pipe diameter air gap is required with a minimum 1" air gap.

Bypass Valves

Always provide for the installation of a bypass valve if unit is not equipped with one.

Recommended Servicing

Due to the nature of AIO valves, it is recommended to replace the injector, air check, piston, seals and spacers, and adapter coupling every 6 to 12 months as needed.

⚠ WARNING: The system **MUST** be depressurized before removing any connections for servicing.

Installation Instructions

1. Place the softener tank where you want to install the unit making sure the unit is level and on a firm base.
2. During cold weather, the installer should warm the valve to room temperature before operating.
3. All plumbing should be done in accordance with local plumbing codes. The pipe size for residential drain line should be a minimum of 1/2 inch (13 mm). Backwash flow rates in excess of 7 gpm (26.5 Lpm) or length in excess of 20 feet (6 m) require 3/4-inch (19 mm) drain line. Commercial drain lines should be the same size as the drain line flow control. Be sure drain lines are secured properly.
4. Refer to the dimensional drawing for cutting height of the distributor tube. If there is no dimensional drawing, cut the distributor tube flush with the top of the tank. The tank should have the distributor tube installed and the proper amount of regenerant in place.
5. Lubricate the distributor o-ring seal and tank o-ring seal. Place the main control valve on tank.

NOTE: Only use silicone lubricant.

6. Solder joints near the drain must be done prior to connecting the Drain Line Flow Control fitting (DLFC). Leave at least 6 inches (15 cm) between the DLFC and solder joints when soldering pipes that are connected on the DLFC. Failure to do this could cause interior damage to the DLFC.
7. Plumber tape is the only sealant to be used on the drain fitting.
8. On units with a bypass, place in bypass position. Turn on the main water supply. Open a cold soft water tap nearby and let run a few minutes or until the system is free from foreign material (usually solder) that may have resulted from the installation. Once clean, close the water tap.
9. Slowly place the bypass in service position and let water flow into the mineral tank. When water flow stops, slowly open a cold water tap nearby and let run until the air is purged from the unit.
10. Plug unit into an electrical outlet.

NOTE: All electrical connections must be connected according to local codes. Be certain the outlet is uninterrupted.

DEFLECTOR INSTALLATION

Put a thin layer of silicone lube around inside diameter of the deflector. Slowly slide the deflector over the distributor tube down about 1". When threading the AIO valve to the tank, the bottom of the threads will slide the deflector down, as shown in the diagram

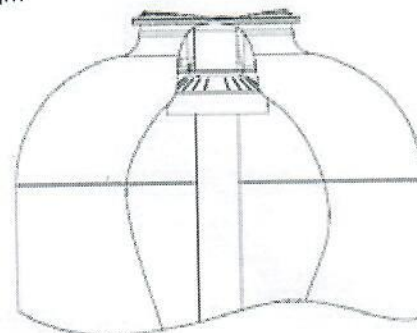

Figure 1

REGENERATION STEPS

Backwash (BW) Cycle Step #1

The backwash cycle (factory set to 10 minutes) washes oxidized contaminants to drain and reclassifies the media bed.

Air Draw (AD) Cycle Step #2

Air Draw (factory set to 60 minutes) empties water from tank and replenishes oxygen to filter media.

Rapid Rinse (RR) Cycle Step #3

Rapid Rinse (factory set to 10 minutes) purges excess atmosphere from the media tank and distributor.

START-UP INSTRUCTIONS

The water softener should be installed with the inlet, outlet, and drain connections made in accordance with the manufacturer's recommendations, and to meet applicable plumbing codes.

1. Initiate a manual regeneration by pressing the Extra Cycle button for 5 continuous seconds on the SXT.
2. During the backwash, air draw, and rapid rinse cycles inspect plumbing for leaks.
3. When the regeneration is complete, the unit will advance automatically into the service position.

TIMER OPERATION

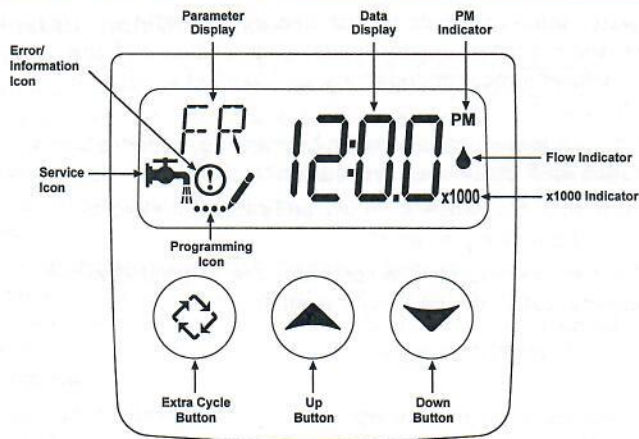

Time Clock Delayed Control

The 2510 AIO SXT uses a Time Clock Delayed control, which regenerates the system on a timed interval. The control will initiate a regeneration cycle at the programmed regeneration time when the number of days since the last regeneration equals the regeneration day override value.

Manually Initiating a Regeneration

1. When timer is in service, press the Extra Cycle button for five seconds on the main screen.
2. The timer advances to Regeneration Cycle Step #1 (backwash), and begins programmed time countdown.
3. Press the Extra Cycle button once to advance valve to Regeneration Cycle Step #2 (air draw).
4. Press the Extra Cycle button once to advance valve to Regeneration Cycle Step #3 (rapid rinse).
5. Press the Extra Cycle button once more to advance the valve back to service.

NOTE: A queued regeneration can be initiated by pressing the Extra Cycle button. To clear a queued regeneration, press the Extra Cycle button again to cancel. If regeneration occurs for any reason prior to the delayed regeneration time, the manual regeneration request shall be cleared.

Control Operation During A Power Failure

The SXT includes integral power backup. In the event of power failure, the control shifts into a power-saving mode. The display and motor shut down, but the control continues to keep track of the time and day for a minimum of 48 hours.

The system configuration settings are stored in a non-volatile memory and are stored indefinitely with or without line power. The Time of Day flashes when there has been a power failure. Press any button to stop the Time of Day from flashing.

If power fails while the unit is in regeneration, the control will save the current valve position before it shuts down. When power is restored, the control will resume the regeneration cycle from the point where power failed. Note that if power fails during a regeneration cycle, the valve will remain in its current position until power is restored. The valve system should include all required safety components to prevent overflows resulting from a power failure during regeneration.

The control will not start a new regeneration cycle without line power. If the valve misses a scheduled regeneration due to a power failure, it will queue a regeneration. Once power is restored, the control will initiate a regeneration cycle the next time that the Time of Day equals the programmed regeneration time. Typically, this means that the valve will regenerate one day after it was originally scheduled.

Setting the Time of Day

1. Press and hold either the Up or Down buttons until the programming icon replaces the service icon and the parameter display reads TD.
2. Adjust the displayed time with the Up and Down buttons.
3. When the desired time is set, press the Extra Cycle button to resume normal operation. The unit will also return to normal operation after 5 seconds if no buttons are pressed.



Queueing a Regeneration

1. Press the Extra Cycle button. The service icon will flash to indicate that a regeneration is queued.
2. To cancel a queued regeneration, press the Extra Cycle button.

Regenerating Immediately

Press and hold the Extra Cycle button for five seconds.

SXT USER PROGRAMMING

Programming Abbreviation	Programming Definition	Default Values	Option Definition
DO	Day Override	3	Days Between Regeneration - In conditions of high water usage and/or high levels of contaminants, the AIO may need to regenerate more frequently than once every three days. DO NOT set the regeneration day override for a longer period than three days, as the filter media can become fouled with contaminants, rendering the AIO ineffective.
RT	Regeneration Time	12:00 AM	Regeneration Time - If there is a need to change the factory default, then make sure the time of regeneration is not the same as any other water treatment equipment in the system.

NOTE: The timer will discard any changes and exit User Mode if any button is not pressed for sixty seconds.

User Programming Mode Steps

1. Press the Up **and** Down buttons for five seconds while in service.
2. Use this display to adjust the Day Override. This option setting is identified by "DO" in the upper left hand corner of the screen.



3. Press the Extra Cycle button. Use this display to adjust the Regeneration Time. This option setting is identified by "RT" in the upper left hand corner of the screen.



4. Press the Extra Cycle button to end User Programming Mode.

DIAGNOSTIC PROGRAMMING MODE

Diagnostic Programming Mode Options		
Abbreviation	Parameter	Description
HR	Hours in Service	Displays the total hours that the unit has been in service
SV	Software Version	Displays the software version installed on the controller

NOTE: The timer will exit Diagnostic Mode after 60 seconds if no buttons are pressed.

Diagnostic Programming Mode Steps

1. Press the Up **and** Extra Cycle buttons for five seconds while in service.
2. Press the Up button. Use this display to view the Hours in Service since the last regeneration cycle. This option setting is identified by "HR" in the upper left hand corner of the screen.

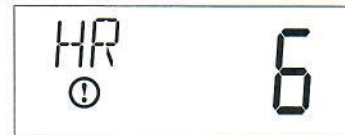

3. Press the Up button. Use this display to view the Software Version. This option setting is identified by "SV" in the upper left hand corner of the screen.



4. Press the Extra Cycle button to end Diagnostic Programming Mode.

2510 AIO SXT

CONTROL VALVE ASSEMBLY

Item No.	QTY	Part No.	Description
1	1	251006-007	Time Clock, AIO Filter, U.S. Transformer, Hardwater Bypass, 1" Deflector, DLFC 4.0 GPM, Environmental Backplate

CONTROL VALVE ASSEMBLY

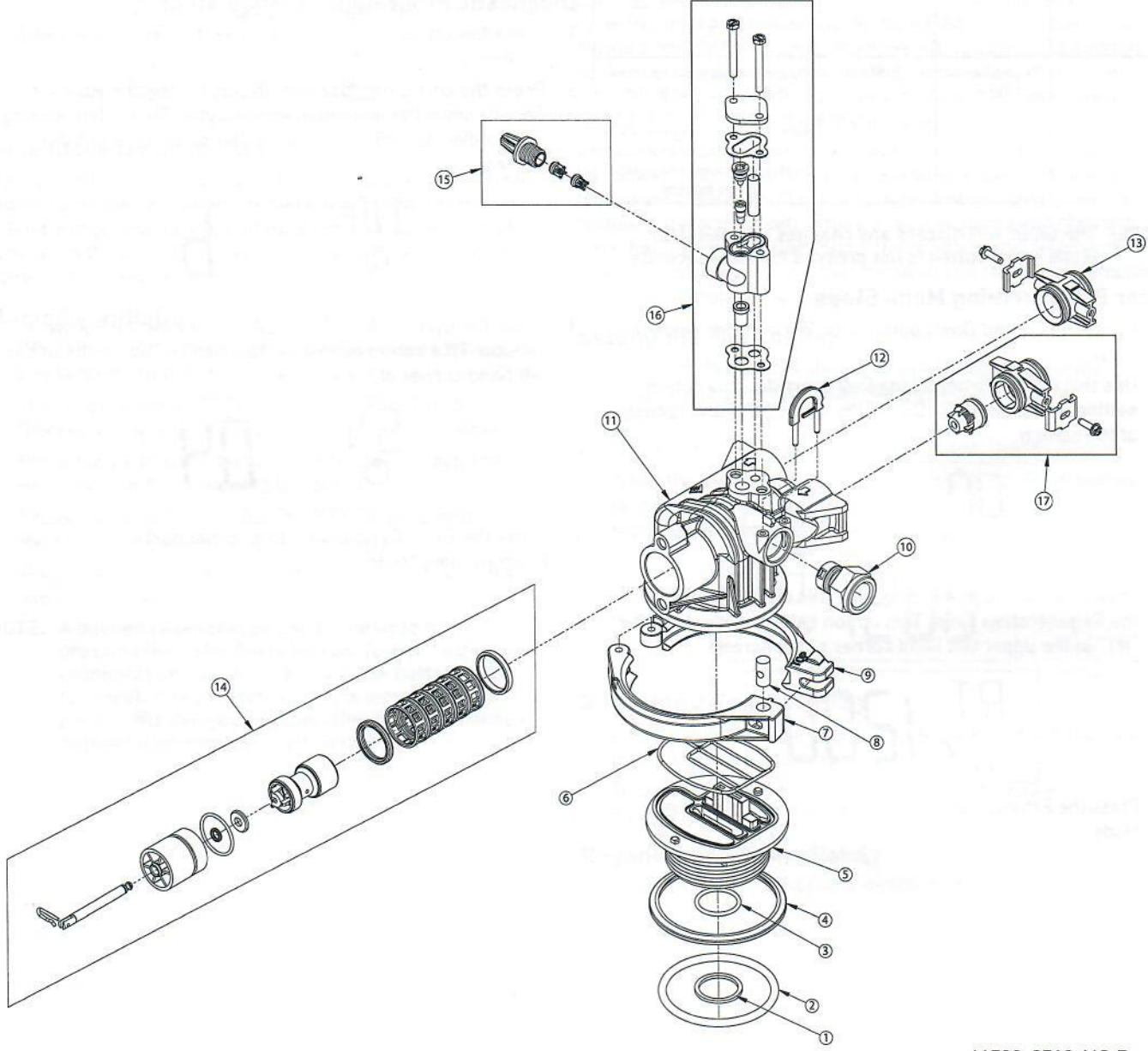

61500-2510 AIO Rev C

CONTROL VALVE ASSEMBLY *CONTINUED*

Item No.	QTY	Part No.	Description
1	1	13030	Retainer, Distributor Tube O-Ring
2	1	18303	O-Ring, -336
3	1	13304	O-Ring, -121
4	1	19197	Ring, Slip, Ladder Valve
5	1	19322	Adapter Base, 2510
6	1	19936	Seal, 2510 Base
7	1	19899	Clamp, Female, 2510
8	1	19998	Pivot, Clamp, 2510
9	1	19900	Clamp, Male, 2510
10	1	60705-40	DLFC, Plastic 4.0 GPM
11	1	19328	Valve Body, 2510
12	1	18312	Retaining Clip
13	1	19228-01	Adapter Assy, Coupling, 5600
14	1	61662-01	Kit, 2510 AIO, Service
15	1	62116	Air Check Assy, 2510
16	1	60480-000	Injector Assy, 1600, #00, Plastic 2750-2900, Complete
		60480-00	Injector Assy, 1600 #0, Plastic 2750-2900, Complete
		60480-01	Injector Assy, 1600 #1, Plastic 2750-2900, Complete
		60480-02	Injector Assy, 1600 #2, Plastic 2750-2900, Complete
		60480-03	Injector Assy, 1600 #3, Plastic 2750-2900, Complete
		60480-04	Injector Assy, 1600 #4, Plastic 2750-2900, Complete
17	1	19228-02	Adapter Assy, Coupling, 2510AIO

Not Shown

1	11098	Stuffer Tool Assy, 2510/2750
1	13061	Puller Assy, Port Ring 2510/2750
1	12874	Hook, Seal
1	1030043	Deflector, 1", Turbulator

POWERHEAD ASSEMBLY

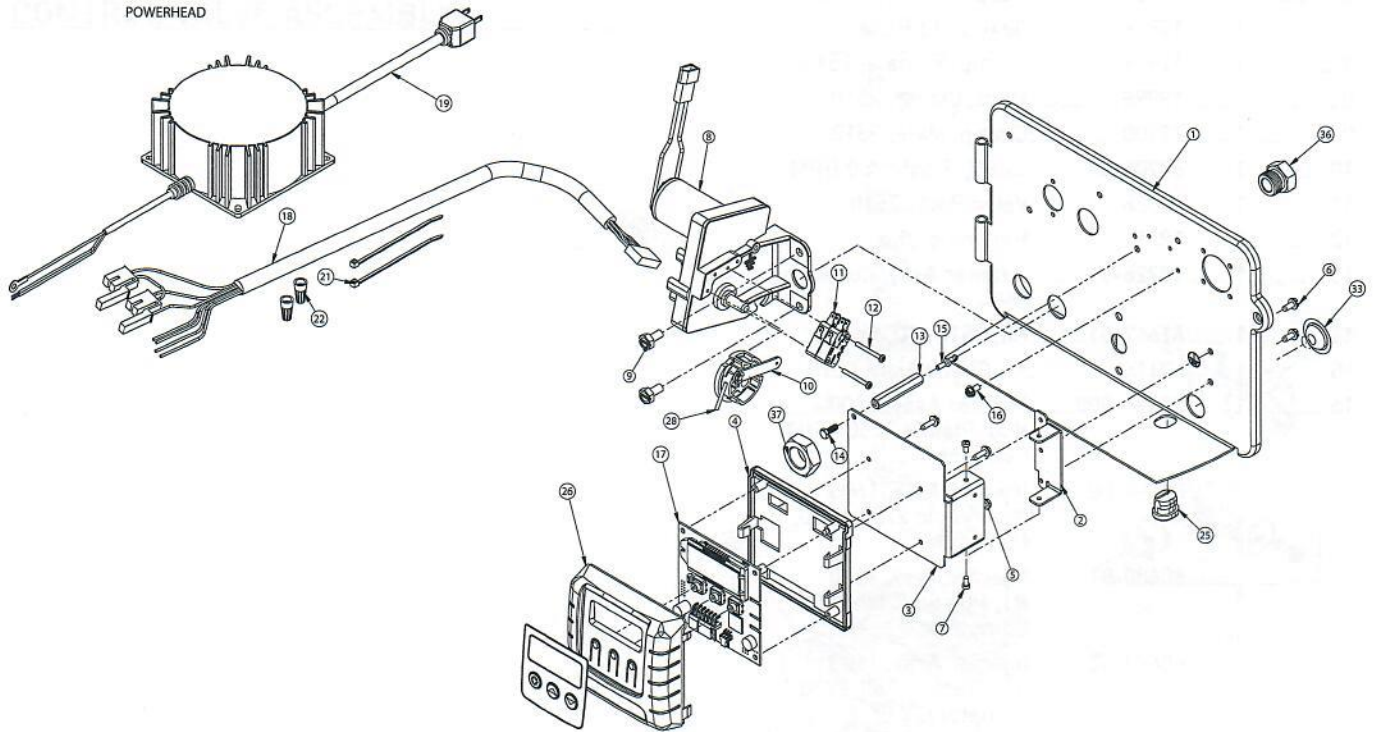

61500-2510 AIO Rev C

POWERHEAD ASSEMBLY *CONTINUED*

Item No.	QTY	Part No.	Description
1	1	18697-15	Backplate, Hinged
2	1	13881	Bracket, Hinge Timer, 900SE
3	1	41546	Bracket, Timer, 2510SXT, 2750SXT
4	1	19889	Housing, Circuit Board
5	4	13296	Screw, Hex Wsh, 6-20 X 1/2
6	2	10300	Screw, Hx Wash Head, 8 x 3/8
7	2	11384	Screw, Phil, 6-32 x 1/4 Zinc
8	1	42579	Motor, Drive, 24VAC/DC, 50-60 Hz Fam 1
9	2	10231	Screw, Slot Hex, 1/4-20 x 1/2
10	1	60160-15	Drive Cam Assy, Stf, Blue, 2900
11	2	10218	Switch, Micro
12	2	14923	Screw, Pan Hd Mach, 4-40 x 1
13	1	27172	Stand-Off, Timer, 2510SE/2750SSE
14	1	21363	Screw, Hex Head, M4 X 12MM
15	1	14265	Clip, Spring
16	1	14202-01	Screw, Hex Washer, #8-32 X 5/16
17	1	44098U	Circuit Board, SXT, Unprgm
18	1	42864	Wire Harness, SXT
19	1	44144	Transformer, US, 24V 40VA, W/O
21	2	14044	Tie, Cable, Plastic
22	2	40422	Wire Nut, Min 2 #22 Wires
25	1	13547-01	Strain Relief, Euro Round Cord
26	1	42635-01	Front Cover, SXT, Square, Black
28	1	10338	Pin, Roll, 3/32 X 7/8
33	1	19691	Plug, .750 DIA. Hole, Flush
36	1	43560	Fitting, Brine Valve, Steel
37	1	10269	Nut, Jam, 3/4-16_v1

2510 VALVE ACCESSORIES

Covers

60219-02Cover Assy, Environmental, Black
w/clear window

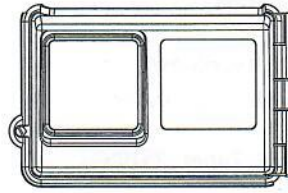

COVER, ENVIRONMENTAL

Bypasses

60041SS.....1" Bypass, SS, NPT
60040SS.....3/4" Bypass, SS, NPT
60049.....Bypass, Plastic

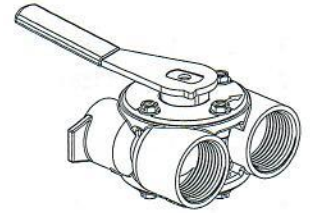

BYPASS

Yokes

19620-01Yoke Assy, 3/4", r/angle, 90 deg.
18706.....1" Yoke, Plastic NPT
18706-101" Yoke, Plastic BSP
18706-023/4" Yoke, Plastic NPT
18706-123/4" Yoke, Plastic BSP
13708-401" Yoke, Sweat
41026-011" Yoke, SS, NPT
42690.....3/4" Yoke, Sweat
41027-013/4" Yoke, SS, NPT

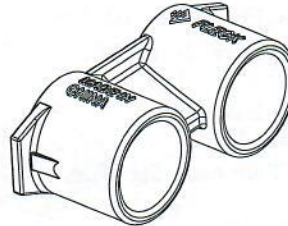

YOKE

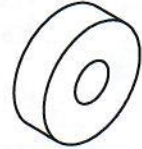

WASHER

Washers

19153.....Washer, Flow, 0.6 GPM
19152.....Washer, Flow, 0.8 GPM
12085.....Washer, Flow, 1.2 GPM
19150.....Washer, Flow, 1.3 GPM
12086.....Washer, Flow, 1.5 GPM
12087.....Washer, Flow, 2.0 GPM
12088.....Washer, Flow, 2.4 GPM
12089.....Washer, Flow, 3.0 GPM
12090.....Washer, Flow, 3.5 GPM
12091.....Washer, Flow, 4.0 GPM
19147.....Washer, Flow, 4.5 GPM
12092.....Washer, Flow, 5.0 GPM
17814.....Washer, Flow, 6.0 GPM
12408.....Washer, Flow, 7.0 GPM
17943.....Washer, Flow, 8.0 GPM
17944.....Washer, Flow, 9.0 GPM
16529.....Washer, Flow, 10.0 GPM
16735.....Washer, Flow, 12.0 GPM
16736.....Washer, Flow, 15.0 GPM

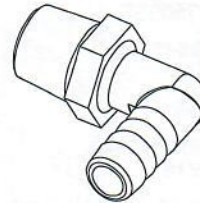

DRAIN ELBOW



HOSE BARBS

Drain Elbows

19699.....1/2" Drain Elbow, 45
13121.....5/8" Drain Elbow, 90



COLLECTOR

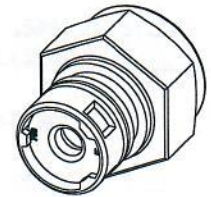

DLFC

Hose Barbs

13308.....1/2" Straight Hose Barb
13308-015/8" Straight Hose Barb

Collectors

18280.....Top Collector, 1.050
18280-01Top Collector, 1.050 Wide
18280-02Top Collector, 1.050 Narrow

DLFC

60705-00DLFC, Plastic, Blank
60706-8.0DLFC, QC x 3/4" F, 8.0 GPM
60706-9.0DLFC, QC x 3/4" F, 9.0 GPM
60706-10DLFC, QC x 3/4" F, 10 GPM
60706-12DLFC, QC x 3/4" F, 12 GPM
60706-15DLFC, QC x 3/4" F, 15 GPM

2510 VALVE CONVERSION ASSEMBLIES

Injector Nozzles

10913-0	Nozzle, Injector, #0, Red (8" Tank)
10913-00	Nozzle, Injector, #00, Violet (7" Tank)
10913-000	Nozzle, Injector, #000, Brown (6" Tank)
10913-1	Nozzle, Injector, #1, White (9" & 10" Tank)
10913-2	Nozzle, Injector, #2, Blue (12" Tank)
10913-3	Nozzle, Injector, #3, Yellow (13" Tank)
10913-4	Nozzle, Injector, #4, Green (14" Tank)

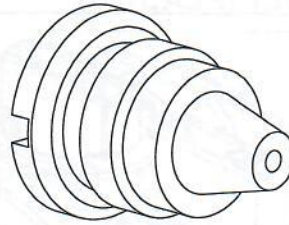

INJECTOR NOZZLE

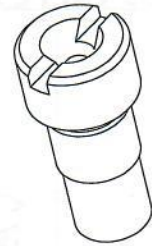

INJECTOR THROAT

Injector Throats

10914-0	Throat, Injector, #0, Red (8" Tank)
10914-00	Throat, Injector, #00, Violet (7" Tank)
10914-000	Throat, Injector, #000, Brown (6" Tank)
10914-1	Throat, Injector, #1, White (9" & 10" Tank)
10914-2	Throat, Injector, #2, Blue (12" Tank)
10914-3	Throat, Injector, #3, Yellow (13" Tank)
10914-4	Throat, Injector, #4, Green (14" Tank)



TIMER ASSY, SXT

Timers

42778	Timer Assy, SXT, 2510/2750/2850
-------	---------------------------------

BYPASS VALVE ASSEMBLY (PLASTIC)

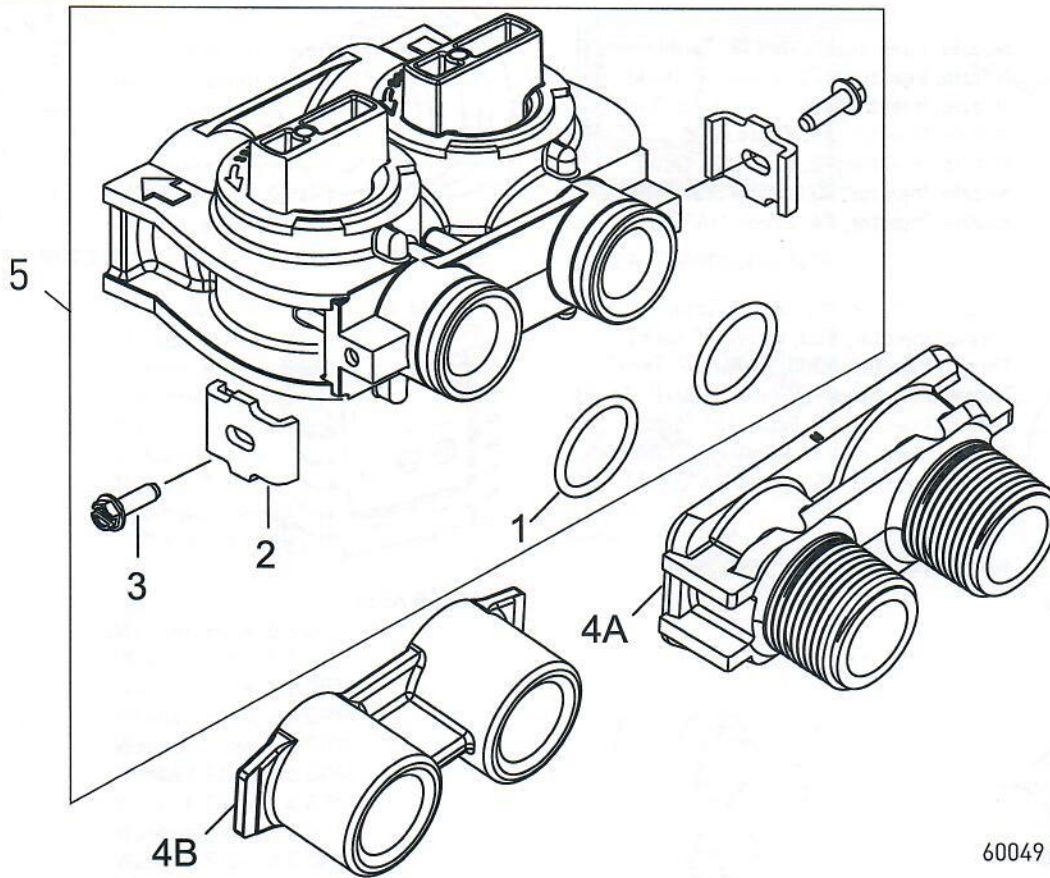

60049 Rev G

Item No.	QTY	Part No.	Description
1	2	13305	O-ring, -119
2	2	13255	Clip, Mounting
3	2	13314	Screw, Slot Ind Hex, 8-18 x .60
4A	1	18706	Yoke, 1-inch , NPT, Plastic
		18706-02	Yoke, 3/4-inch , NPT, Plastic
4B	1	13708-40	Yoke, 1-inch , Sweat
		42690	Yoke, 3/4-inch, Sweat, Brass
		41027-01	Yoke, 3/4-inch , NPT, Cast, Machined
		41026-01	Yoke, 1-inch , NPT, Cast, Machined, SS
		18706-10	Yoke, 1-inch , BSP, Plastic
		18706-12	Yoke, 3/4-inch , BSP, Plastic
		19620-01	Yoke Assy, 3/4-inch , R/ Angle, 90 Deg
5	1	60049	Bypass Plastic
*	2	19228-01	Adapter Assy, Coupling, w/O-rings

*Not Shown

BYPASS VALVE ASSEMBLY (METAL)

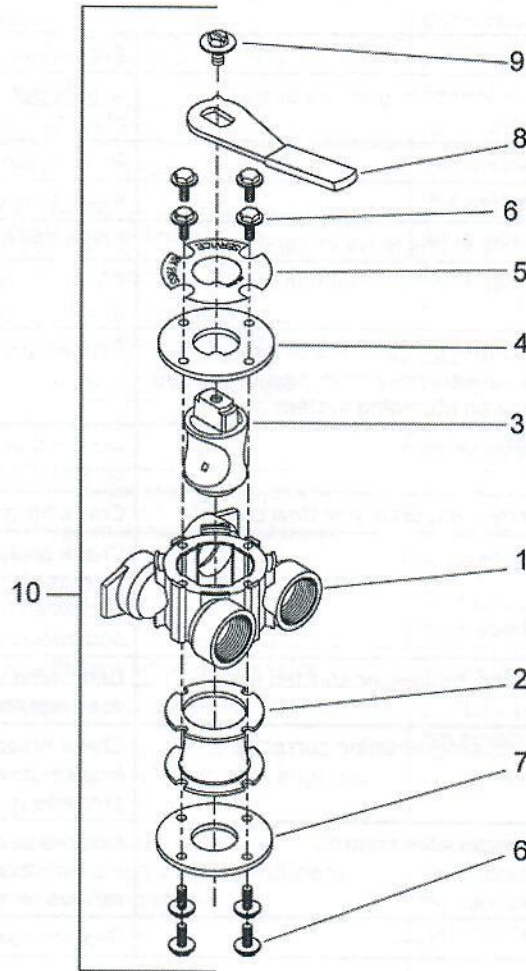

60040SS Rev T
60041SS Rev U

Item No.	QTY	Part No.	Description
1	1	40614	Bypass Body, 3/4-inch
		40634	Bypass Body, 1-inch, SS
2	1	14105	Seal, Bypass, 560CD
3	1	11972	Plug, Bypass
4	1	11978	Side Cover
5	1	13604-01	Label
6	8	15727	Screw, 10-24 x 0.5-inch
7	1	11986	Side Cover
8	1	11979	Lever, Bypass
9	1	11989	Screw, Hex Head, 1/4-14 x 1.5-inch
10	1	60040SS	Bypass Valve, 5600, 3/4-inch NPT Blk Grip Lever, SS
	1	60041SS	Bypass Valve, 5600, 1-inch NPT Blk Grip Lever, SS
*	2	19228-01	Adapter Assy, Coupling, w/O-rings

*Not Shown

TROUBLESHOOTING (2510)

Problem	Cause	Correction
Water conditioner fails to regenerate.	Electrical service to unit has been interrupted	Assure permanent electrical service (check fuse, plug, pull chain, or switch)
	Timer is defective.	Replace timer.
	Power failure.	Reset time of day.
Loss of water pressure.	Iron buildup in line to water conditioner.	Clean line to water conditioner.
	Iron buildup in water conditioner.	Clean control and add mineral cleaner to mineral bed. Increase frequency of regeneration.
	Inlet of control plugged due to foreign material broken loose from pipes by recent work done on plumbing system.	Remove piston and clean control.
Loss of mineral through drain line.	Air in water system.	Assure that well system has proper air eliminator control. Check for dry well condition.
	Improperly sized drain line flow control.	Check for proper drain rate.
Iron in conditioned water.	Fouled mineral bed.	Check backwash, brine draw, and brine tank fill. Increase frequency of regeneration. Increase backwash time. Check iron buildup on check valve and piston.
Control cycles continuously.	Misadjusted, broken, or shorted switch.	Determine if switch or timer is faulty and replace it, or replace complete power head.
Drain flows continuously.	Valve is not programming correctly.	Check timer program and positioning of control. Replace power head assembly if not positioning properly.
	Foreign material in control.	Remove power head assembly and inspect bore. Remove foreign material and check control in various regeneration positions.
	Internal control leak.	Replace seals and piston assembly.

TROUBLESHOOTING (AIO)

Problem	Cause	Correction
1. Unit does not go through air draw cycle	A. Electrical service to unit is interrupted.	A. Inspect power supply and correct if necessary.
	B. Power failure	Reset time of day
	C. Timer is defective	C. Verify that dial showing days moves from day today. If it does not move, replace timer.
2. Unit does not draw air	A. Drain line is kinked	A. Straighten drain line
	B. Water pressure to unit too low	B. Pressure must be above 20 psi at all times. Increase pressure if necessary.
	C. Drain line flow control blocked	C. Inspect DLFC and clean if necessary.
	D. Injectors or screen plugged	D. Inspect and clean or replace as necessary.
	E. Internal leak in control	E. Inspect piston and seals/spacers. Replace as needed.
3. Water flows continuously to drain	A. Timer motor stopped or jammed	A. Replace if necessary.
	B. Foreign material jammed inside control	B. Remove piston and check.
	C. Internal leak	C. Inspect piston and seals/spacers. Replace as needed.
4. Water is clear from tap, turns red upon standing	A. Insufficient air drawn by valve	A. Check valve at air draw time
	B. Bypass open or leaking	B. Close bypass valve and/or repair as necessary
	C. Filter bed backwashed at improper frequency	C. Increase backwash frequency.
5. Water is red when drawn from tap	A. Filter bed overloaded with precipitated iron due to insufficient backwash flow rate.	A. Inspect drain line for kinks or obstructions. Verify drain line flow control is correct size for application. If, after correction, manual backwash does not clear bed of iron, filter bed may need chemical washing.
	B. Filter bed backwashed at improper frequency	B. Increase backwash frequency.
6. Excessive pressure loss through filter	A. Filter bed overloaded with precipitated iron.	A. Inspect drain line for kinks or obstructions. Verify drain line flow control is correct size for application. If, after correction, manual backwash does not clear bed of iron, filter bed may need chemical washing.
	B. Control in/outlet valves not fully open.	B. Open valves
	C. Sand, silt, or mud collecting in filter media	C. Inspect well for these conditions.
	D. Filter bed not properly "classified"	D. Manually backwash to reclassify.
	E. "Cementing" or "channelling" of filter media.	E. Stir filter bed to break up hardened layer. Increase backwash frequency to prevent recurrence.
7. Milky or bubbly water.	A. Excess gasses in water.	A. System may require cleaning. Some installations will naturally produce aerated water.
8. Control cycles continuously.	A. Misadjusted, broken, or shorted switch.	A. Determine if switch or timer is faulty and replace it, or replace complete power head.
9. Drain flows continuously.	A. Valve is not programming correctly.	A. Check timer program and positioning of control. Replace power head assembly if not positioning properly.
	B. Foreign material in control.	B. Remove power head assembly and inspect bore. Remove foreign material and check control in various regeneration positions.
	C. Internal control leak.	C. Replace seals and piston assembly.

FLOW DATA & INJECTOR DRAW RATES

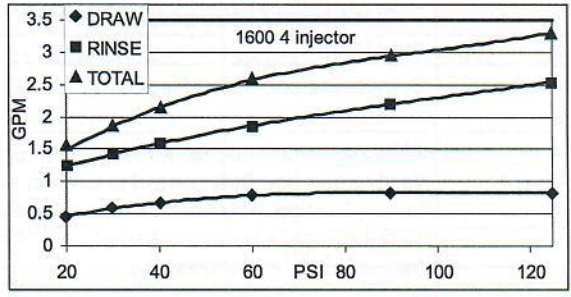
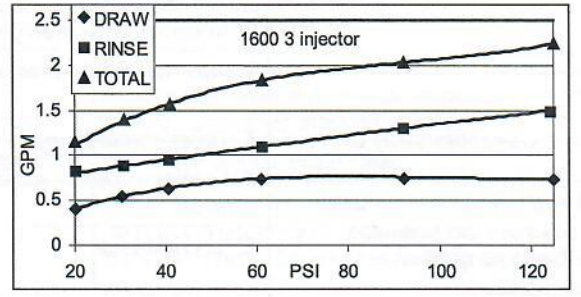
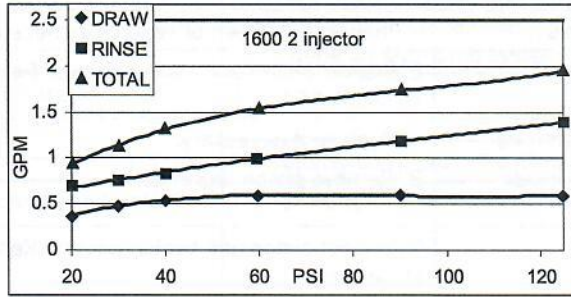
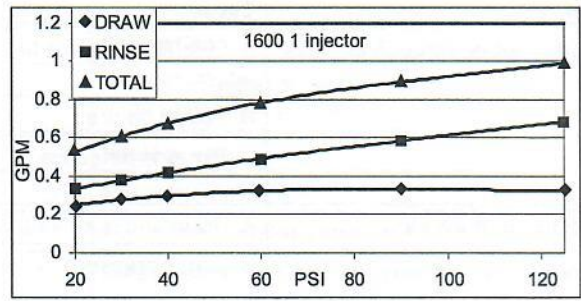
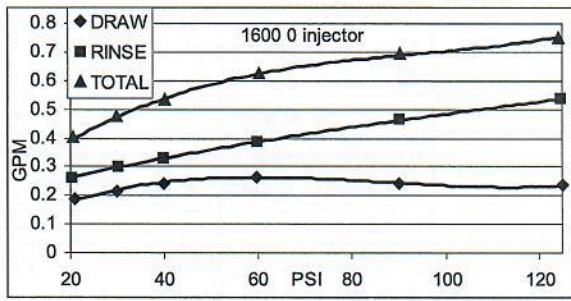

TR20391_REVA

SXT WIRING DIAGRAM

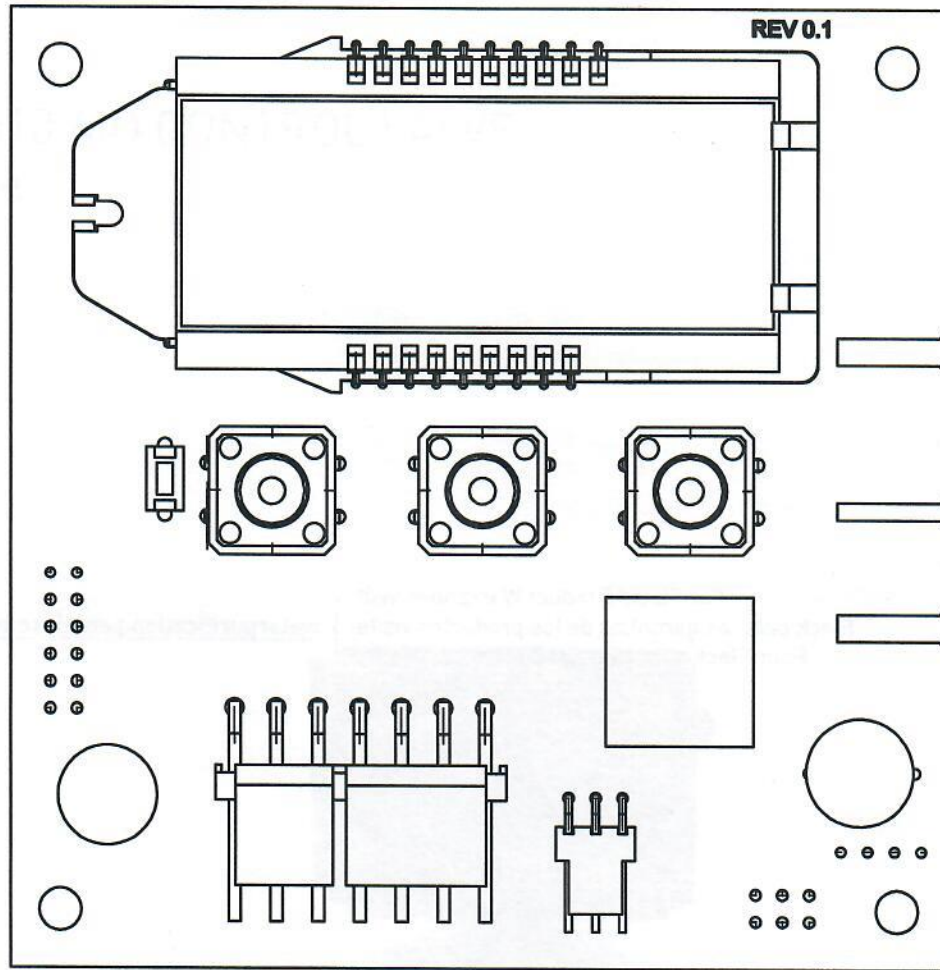

P2
POWER HARNESS

P1
METER

44098U REV D

For Fleck[®] Product Warranties visit: }
Fleck para las garantías de los productos visite: } waterpurification.pentair.com
Pour Fleck garanties produit visitez le site : }



13845 BISHOPS DR., SUITE 200, BROOKFIELD, WI 53005
WATERPURIFICATION.PENTAIR.COM | CUSTOMER CARE: 800.279.9404 | tech-support@pentair.com

© 2018 Pentair Residential Filtration, LLC. All rights reserved.

§For a detailed list of where Pentair trademarks are registered, please visit waterpurification.pentair.com/brands. Pentair trademarks and logos are owned by Pentair plc or its affiliates. Third party registered and unregistered trademarks and logos are the property of their respective owners.

44425 REV A JL18